

D-SERIES COMPRESSED AIR FILTER

FILTER HOUSINGS SPECIFICATIONS

Description	Housings designed for application in non-aggressive compressed air systems.
Housing Material	Cast aluminium
Maximum Operating Pressure	16 bar (232 psi) for model D02-D26 ; 12 bar (174 psi) for model D30-D32
Protective Coating	Chromatisation
External Coating	Powder coated
Inlet and Outlet Port	BSP Threaded (NPT available upon request)
Element Securing Method	Push-To-Fit

STANDARD AND OPTIONAL ACCESSORIES

Filter Element	Five filtration grades available (Refer to table below)
Condensate Drain	Standard mechanical float auto-drains for 16 bar filters.
Differential Pressure Measurement	Differential pressure gauge

FILTRATION GRADE

Grade-P Particulate Filter	Particle removal down to 3 micron
Grade U Coalescing Filter	Particle removal down to 1.0 micron. Oil removal down to 0.1 mg/m3
Grade H Coalescing Filter	Particle removal down to 0.01 micron. Oil removal down to 0.01 mg/m3
Grade S Coalescing Filter	Particle removal down to 0.01 micron. Oil removal down to 0.001 mg/m3
Grade C Act. Carbon Filter	Oil removal down to 0.003 mg/m3

STANDARD FACTORY TEST

For Housing	Hydrostatic Test with water pressure at 1.5 times max design pressure
For Housing	Leakage Test with air pressure at about 7 bar (101.5 psi)
For Element	Integrity Test with pressurized particles of 0.2-20 micron

FILTER MODEL (16 BAR / 232 PSI MAX)

Model	Type	Conn.	Cap. m ³ /min	Cap. cfm	Approx. Weight (kg)	Approx. Dimensions, mm				Element Type
						A	B	C	D	
D02	Threaded	1/4"	0.83	29.41	0.77	104	193.5	96.4	55	EDA02
D04	Threaded	3/8"	1.25	44.12	0.79	104	216.5	96.4	65	EDA04
D06	Threaded	1/2"	1.83	64.71	0.82	104	216.5	96.4	75	EDA06
D08	Threaded	3/4"	2.83	100.00	0.87	104	266.5	96.4	125	EDA08
D10	Threaded	1"	5.00	176.47	1.87	148	276.8	137.7	110	EDA10
D12	Threaded	1 1/2"	8.33	294.12	2.18	148	346.8	137.7	180	EDA12
D14	Threaded	1 1/2"	10.83	382.35	2.64	148	486.8	137.7	270	EDA14
D16	Threaded	1 1/2"	13.33	470.59	2.70	148	486.8	137.7	320	EDA16
D20	Threaded	2"	16.67	588.24	7.17	197	603.6	190.4	330	EDA20
D22	Threaded	2"	21.67	764.71	8.22	197	703.6	190.4	430	EDA22
D24	Threaded	2 1/2"	29.17	1029.41	9.24	197	803.6	190.4	530	EDA24
D26	Threaded	2 1/2"	37.17	1311.76	10.26	197	903.6	190.4	630	EDA26
D30	Threaded	3"	43.33	1529.41	13.70	255	752.2	207.8	450	EDA30
D32	Threaded	3"	50.00	1764.71	15.03	255	852.2	207.8	550	EDA32

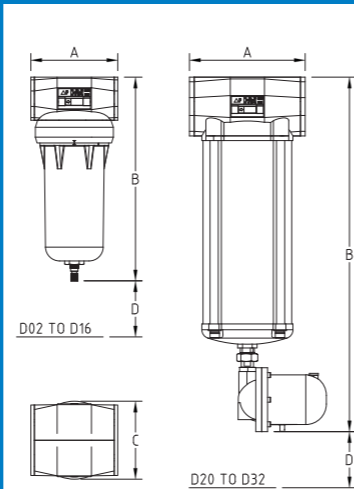

Note: Capacities at FAD, 7 bar g. Please contact us for details on higher pressure systems.



P-Grade U-Grade H-Grade S-Grade C-Grade

Airfilter Engineering reserves the right to change specifications without prior notice (REV V3/10/15.)



COMPRESSED AIR FILTERS

High efficiency filtration for clean & technically oil-free compressed air

D-SERIES

Engineering Solutions to Cleaner Air

Filtration Solutions for Compressed Air Applications

Compressed air, next to electricity, is the most widely used energy source in the industry section.

Energy cost continue to rise global with a negative effect on production cost. Sustainable energy saving initiatives in plant operations have to be implemented in order to cover back some of the negative cost effects.

Air treatment manufacturers like AFE are challenged to design products which are cost effective without losing performance specified in international standard's. Hence, the following aspects have to be considered in high quality compressed air purification:

- Economic filtration
- Validated performance data according to ISO 12500-1 (oil aerosols), 12500-2 (oil vapours) and 12500-3 (particles)
- Reliable achievement of the compressed air quality to suit the application according to ISO 8573-1

The AFE D-Series new generation Filters are designed to fulfill all these needs, given the customer the ideal solution of energy efficiency while complying to these standards.

Nature And Extent Of Air Impurities

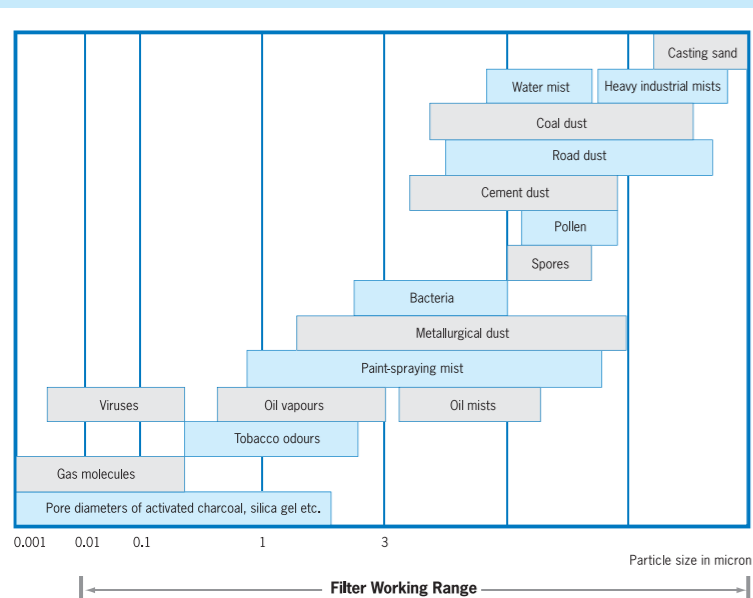

AFE Filter Grades

Airfilter Engineering (AFE) has developed a comprehensive range of filter grades to cater to the requirements of different applications. All our filter media are of pleated design to ensure higher filtration area. Here at AFE, filters and elements can also be custom-made to suit your needs.

- P**
- AFE Filter Grade P**
- For coarse pre-filtration
 - Particle removal down to 3 micron
- U**
- AFE Filter Grade U**
- For general filtration
 - Particle removal down to 1 micron
 - Oil content down to 0.1 mg/m³ at 20°C
- H**
- AFE Filter Grade H**
- For high performance filtration
 - Particle removal down to 0.01 micron
 - Oil content down to 0.01 mg/m³ at 20°C
- S**
- AFE Filter Grade S**
- For high performance filtration
 - Particle removal down to 0.01 micron. Oil content down to 0.001 mg/m³ at 20°C in conjunction with filter grade H
- C**
- AFE Filter Grade C**
- Activated carbon filter. For odour removal. Applicable in oil lubricated compressors.
 - For removal of oil content down to 0.003 mg/m³ at 20°C in conjunction with filter grade H

Accessories

- Internal Auto Drain**
IAD 516A
CODE = I5A
- External Auto Drain**
EAD 416
CODE = E4
- Electronic Timer Drain**
ETD216
CODE = T2
- Electronic Zero Loss Drain**
ESD100
CODE = Z1
- Semi Auto Drain**
SAD 116 (for D02 - D16)
CODE = S1
- Semi Auto Drain**
SAD 216 (for D20 - D32)
CODE = S2



The basic benefits that we can offer with our pleated filter media are:

- Higher effective filtration area
- Higher dirt holding capacity
- Lower pressure drop
- Possibility of higher air flow



ISO 8573-1 : 2010 - TABLE OF CONTAMINANTS AND PURITY CLASSES							
Purity Class	PARTICLES			HUMIDITY AND LIQUID WATER		OIL	
	Maximum number of particles per cubic metre as a function of particle size, d			Mass Concentration C	Pressure Dewpoint	Concentration Of Liquid Water, C	Concentration Of Total Oil (Liquid, Aerosol & Vapour)
	0.1 µm < d ≤ 0.5 µm	0.5 µm < d ≤ 1.0 µm	1.0 µm < d ≤ 5.0 µm	mg/m ³	°C	g/m ³	mg/m ³
0	As specified by the equipment user or supplier and more stringent than Class 1						
1	≤ 20 000	≤ 400	≤ 10	-	≤ -70	-	≤ 0.01
2	≤ 400 000	≤ 6 000	≤ 100	-	≤ -40	-	≤ 0.1
3	Not specified	≤ 90 000	≤ 1 000	-	≤ -20	-	≤ 1
4	Not specified	Not specified	≤ 10 000	-	≤ +3	-	≤ 5
5	Not specified	Not specified	≤ 100 000	-	≤ +7	-	-
6	-	-	-	0 < C _p ≤ 5	≤ +10	-	-
7	-	-	-	5 < C _p ≤ 10	-	C _w ≤ 0.5	-
8	-	-	-	-	-	0.5 < C _w ≤ 5	-

The ISO 8573-1 is a key element of the ISO 8573 series of documents and it specifies the various purity classes of compressed air with respect to particles, water and oil.
 EXAMPLE OF DESIGNATION:
 ISO 8573-1:2010 [1:2:1] indicate,
 - purity Class 1 for particles
 - purity Class 2 for humidity and liquid water
 - purity Class 1 for oil